

1 A-A' SECTION
Head jamb and SILL

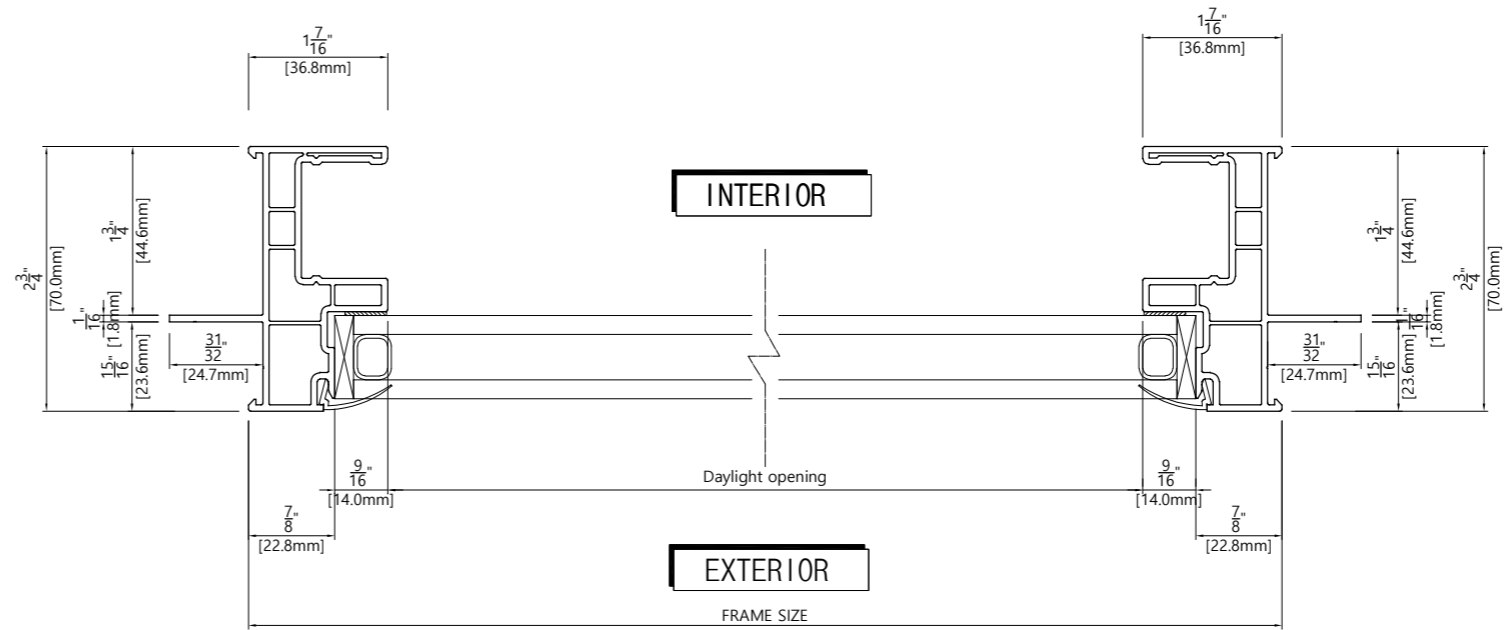

3 B-B' SECTION
JAMB

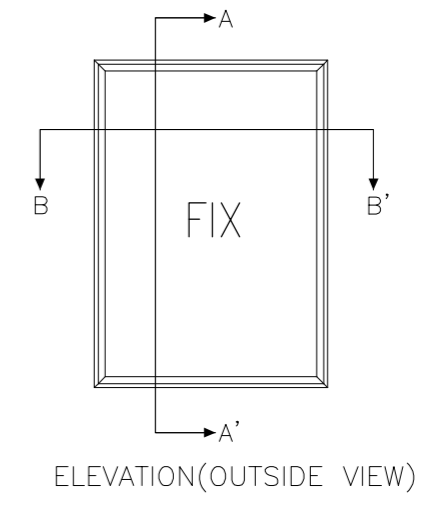

SYSTEM

NOTE.

REV.	DESCRIPTION	DATE
△		
△		
△		
△		
△		
△		

CODE NO.
U PVC Fixed Window

PROJECT TITLE

DRAWING NAME

DRAWING BY

CHECKED BY

APPROVED BY

FILE NAME

DATE

DRAWING NO